

SURNAME FIRST NAME
(Block capitals, please)
JUNIOR SCHOOL SENIOR SCHOOL



Independent Schools
Examinations Board

COMMON ENTRANCE EXAMINATION AT 13+

MATHEMATICS

PAPER 3

Calculator Paper

Tuesday 24 February 2004

Please read this information before the examination starts.

- This examination is 60 minutes long.
- **All** questions should be attempted.
- A row of dots denotes a space for your answer.
- Where answers are not exact they should be given to three significant figures, unless specified otherwise.
- The π button on your calculator should be used for calculations involving π .

1. (a) (i) Writing down all the figures shown on your calculator, find the value of

$$\frac{3.5 + 2.9}{1.8 \times 0.34}$$

Answer: (2)

- (ii) Write your answer to part (i) correct to the nearest whole number.

Answer: (1)

- (iii) Write your answer to part (i) correct to one decimal place.

Answer: (1)

- (b) My car travels 8.9 miles on 1 litre of petrol.

How many litres of petrol does the car use on a journey of 175 miles?
Give your answer to the nearest 0.1 litre.

Answer: litres (2)

2. In an election there were 35 640 votes cast for all of the candidates.

Mr Bragg gained exactly 65% of the votes cast.

(i) (a) How many votes did Mr Bragg receive?

Answer: (2)

(b) What was the total number of votes cast for the other candidates?

Answer: (1)

Miss Fortune gained 50% of these remaining votes.

(ii) How many votes did Miss Fortune receive?

Answer: (1)

(iii) By how many votes did Mr Bragg beat Miss Fortune in the election?

Answer: (1)

(iv) By what percentage of the total votes cast did Mr Bragg beat Miss Fortune?

Answer:% (2)

3. Anthony buys a 500 gram 'large' jar of pickle costing £2.95 and a 300 gram 'economy' jar of the same type of pickle costing £1.98



- (i) Find the cost of 100 grams of pickle from each of the jars.

Answer: 100 grams from the large jar cost pence
100 grams from the economy jar cost pence (3)

Anthony pours the contents of the two jars into an empty pot and mixes them.

- (ii) What is the cost of 100 grams of the mixture in the pot?

Give your answer to the nearest penny.

Answer: pence (2)

4. The diagram shows a circular birthday cake of diameter 25 cm and depth 8 cm.

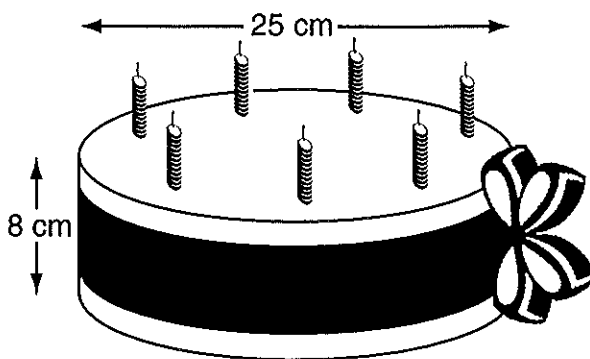

(i) Calculate the area of the top of the cake.

Answer: cm^2 (3)

(ii) A ribbon is tied round the circumference of the cake.

If 20 cm of ribbon are needed to tie the knot, calculate the total length of the ribbon.

Answer: cm (3)

(iii) The cake, without its candles, fits snugly into a box in the shape of a cuboid.

Calculate the volume of the empty box.

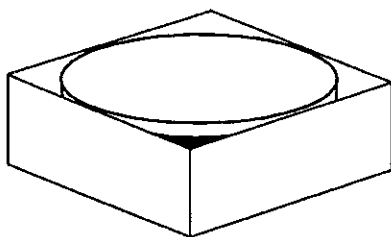

Answer: cm^3 (2)

5. Mr Rush catches the London to Newcastle train which leaves London at 17 : 30
The train arrives in Newcastle $3\frac{3}{4}$ hours later.

(i) Calculate the time at which the train arrives in Newcastle.

Answer: (2)

(ii) Calculate the average speed of the train, in miles per hour, on the journey
from London to Newcastle, a distance of 300 miles.

Answer: mph (2)

When Mr Rush arrives in Newcastle, he catches a taxi home which takes
15 minutes at an average speed of 24 mph.

(iii) How far does Mr Rush travel in the taxi?

Answer: miles (2)

6. Calculate the size of each of the angles marked a , b , c and d .

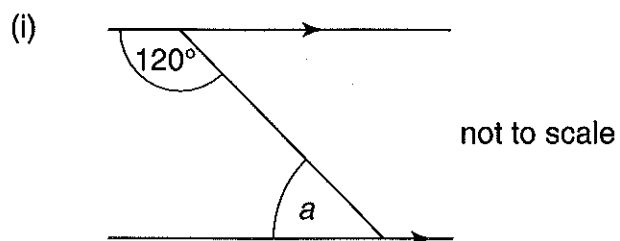

Answer: $a = \dots\dots\dots^\circ$ (1)

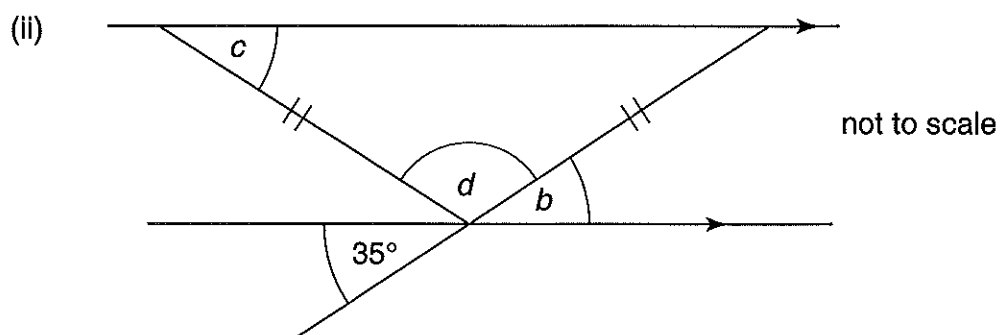

Answer: $b = \dots\dots\dots^\circ$ (1)

Answer: $c = \dots\dots\dots^\circ$ (2)

Answer: $d = \dots\dots\dots^\circ$ (2)

7. The temperature at noon on each of the first ten days in February is given in the table below.

date	1st	2nd	3rd	4th	5th	6th	7th	8th	9th	10th
temp. (°C)	10	8	6	4	4	5	5	2	4	6

Calculate

- (i) the range of temperatures

Answer: degrees (2)

- (ii) the modal temperature

Answer: °C (1)

- (iii) the median temperature

Answer: °C (2)

- (iv) the mean temperature.

Answer: °C (2)

(v) Complete the line graph.

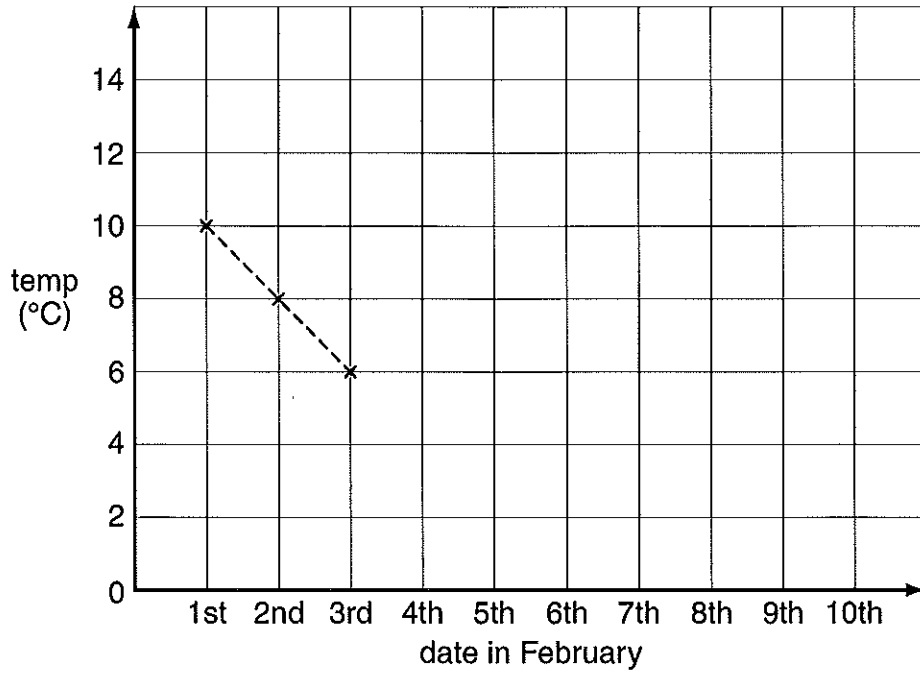

(2)

8. (a) Factorise completely

$$6n - 18$$

Answer: (2)

(b) Multiply out the brackets and simplify

$$3(p + 2q) - (p + q)$$

Answer: (3)

9. In a game of numbers, Alice chooses a number n .

Brenda chooses a number which is four more than Alice's number.

(i) Write down an expression, in terms of n , for Brenda's number.

Answer: (1)

Caroline chooses a number which is twice Alice's number.

(ii) Write down an expression, in terms of n , for Caroline's number.

Answer: (1)

(iii) Write down an expression, in terms of n , for the sum of the three numbers.
Simplify your answer.

Answer: (2)

The sum of the three numbers is zero.

(iv) Form an equation and solve it to find the number which Alice chose.

Answer: $n =$ (2)

10. (i) With centre P , enlarge the shape S using a scale factor of 2
 Label the enlarged shape T .

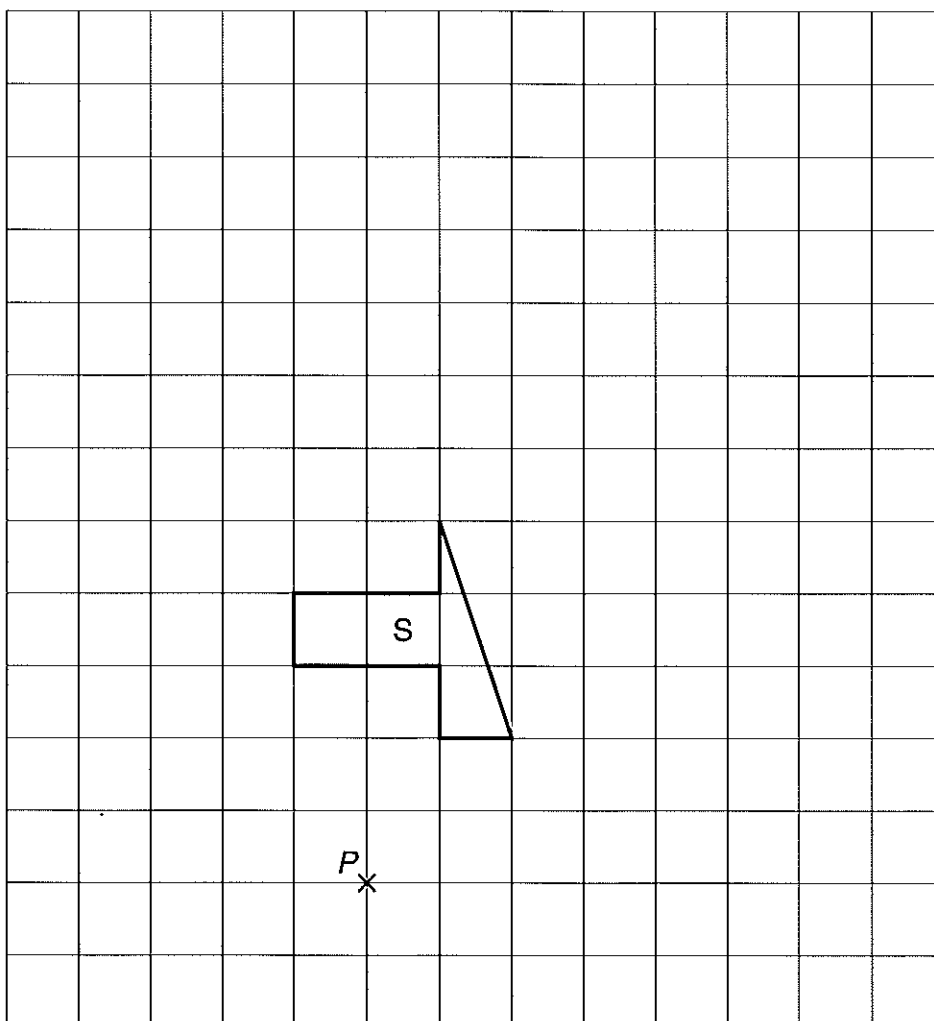

(3)

S is drawn on a 1 centimetre square grid.

- (ii) Find the area in the shape S .

Answer: cm^2 (2)

- (iii) Hence, or otherwise, find the area of the enlarged shape T .

Answer: cm^2 (2)

11. $ABCD$ is part of a regular polygon with exterior angles of 40°
 The point O is the centre of the polygon.

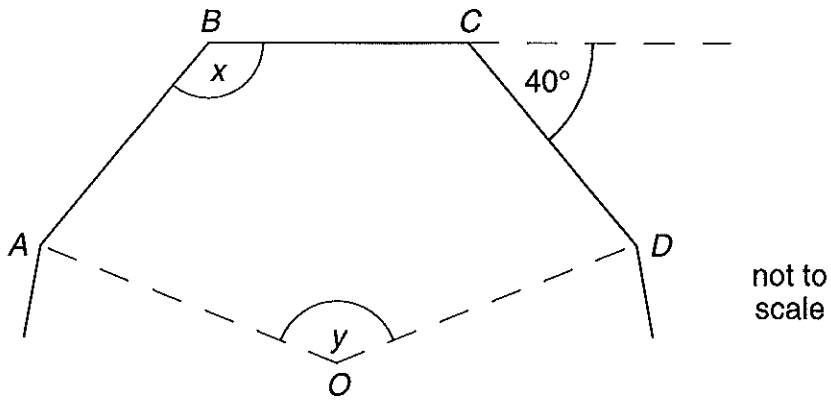

For this regular polygon, calculate

- (i) the total number of sides

Answer: (2)

- (ii) the size of each interior angle, x

Answer: $x = \dots\dots\dots^\circ$ (1)

- (iii) the sum of all the interior angles of the polygon

Answer:^o (2)

- (iv) the size of the angle y .

Answer: $y = \dots\dots\dots^\circ$ (2)

12. In this question use the conversion

1 pound (£) is equal to 1.6 euros (€)

(i) What is the value, in euros, of £35?

Answer: € (1)

(ii) Complete the scales and draw a graph to show the conversion of pounds to euros up to £35

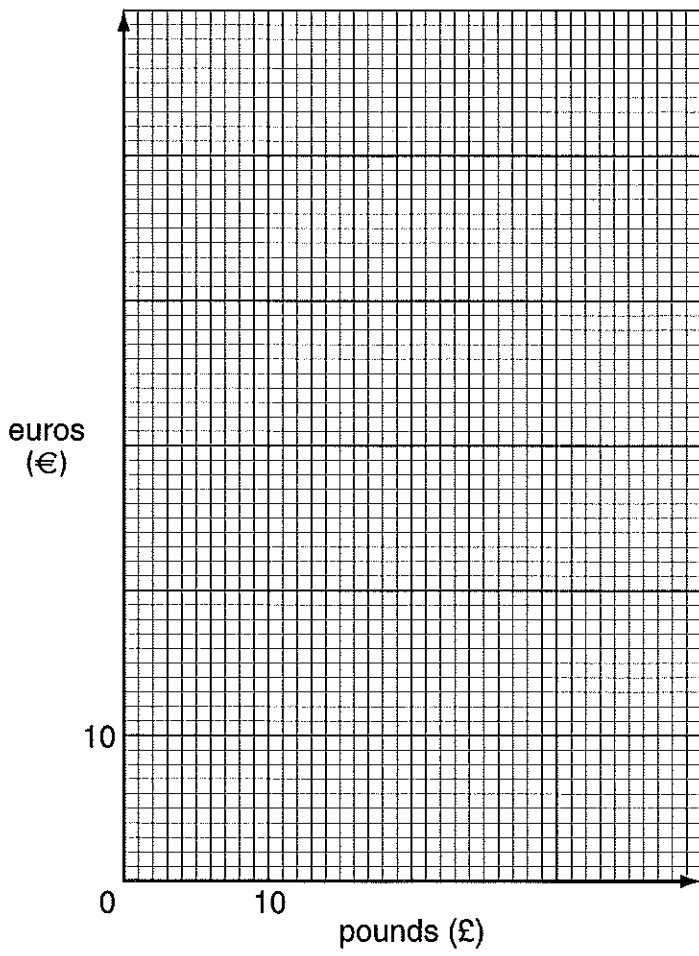

(3)

(iii) Showing clearly where you take your reading, use your graph to find

(a) how many euros Tim can exchange for £15

Answer: € (2)

(b) how many pounds Jacques will receive for €45

Answer: £ (2)

13. Here are the first three patterns in a sequence, using 1 centimetre lines drawn on dotted paper.

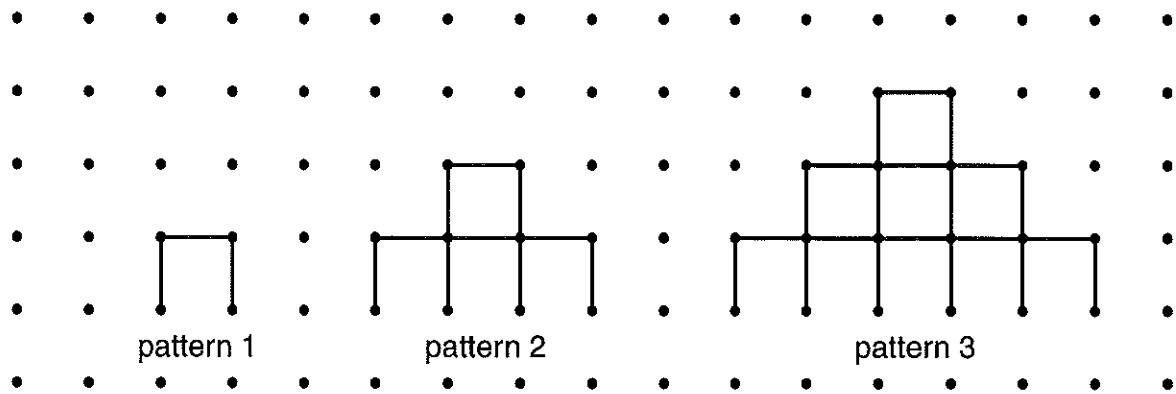

(i) Draw the next pattern in the sequence. You may wish to leave space to draw other patterns later.

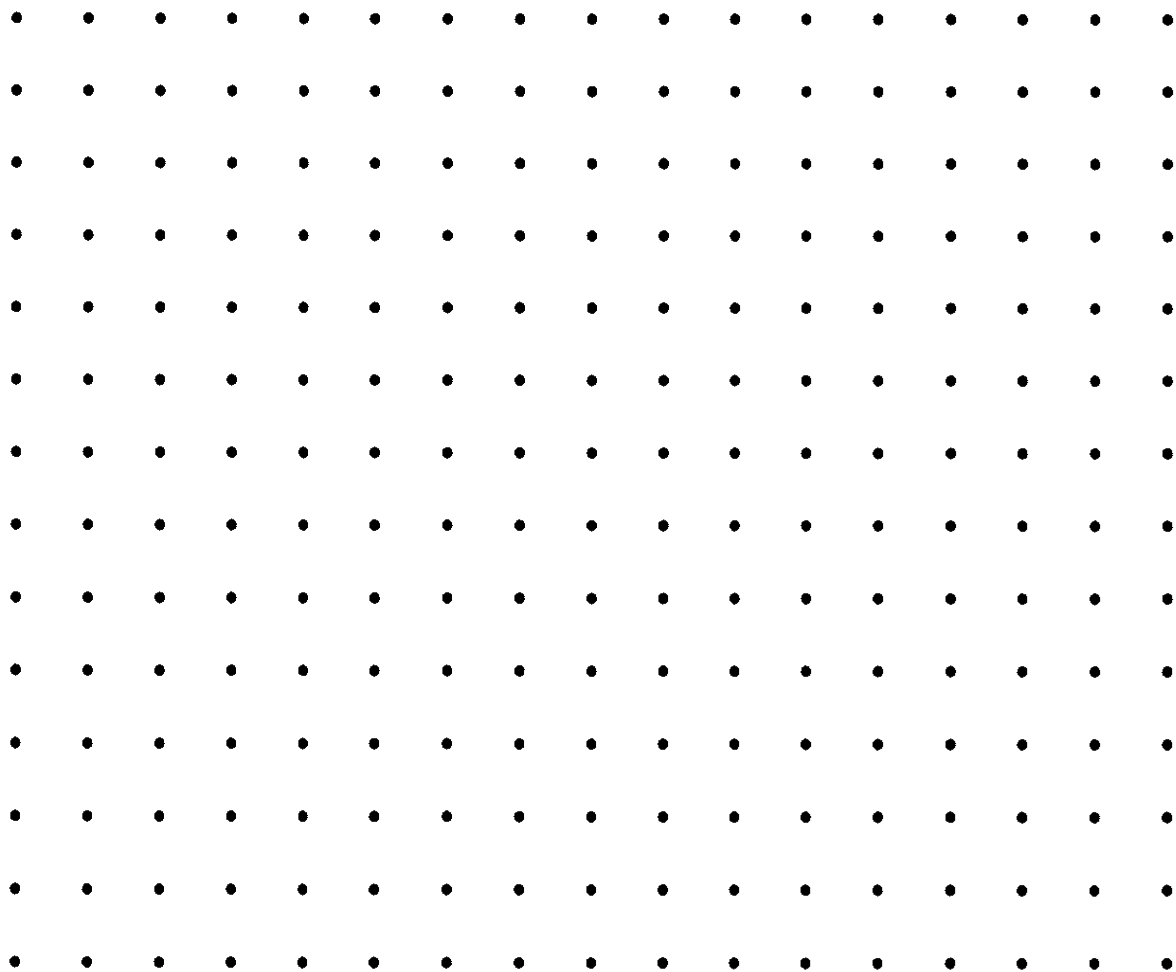

(2)

(ii) Complete the following table of values for pattern numbers 3 to 5

pattern number	number of dots along the base	total number of dots	number of vertical 1 cm lines	number of horizontal 1 cm lines
1	2	4	2	1
2	4	10	6	4
3				
4				
5				

(4)

(iii) By considering the sequence of numbers in each column, complete the table of values for pattern number 8

8				
---	--	--	--	--

(4)

14. (i) Complete the table below for each of the following functions:

(a) $y = x + 1$

x	0	2	6
y			

(2)

(b) $y = 9 - x$

x	2	5	7
y			

(2)

(ii) On the grid below, draw the graphs of $y = x + 1$ and $y = 9 - x$

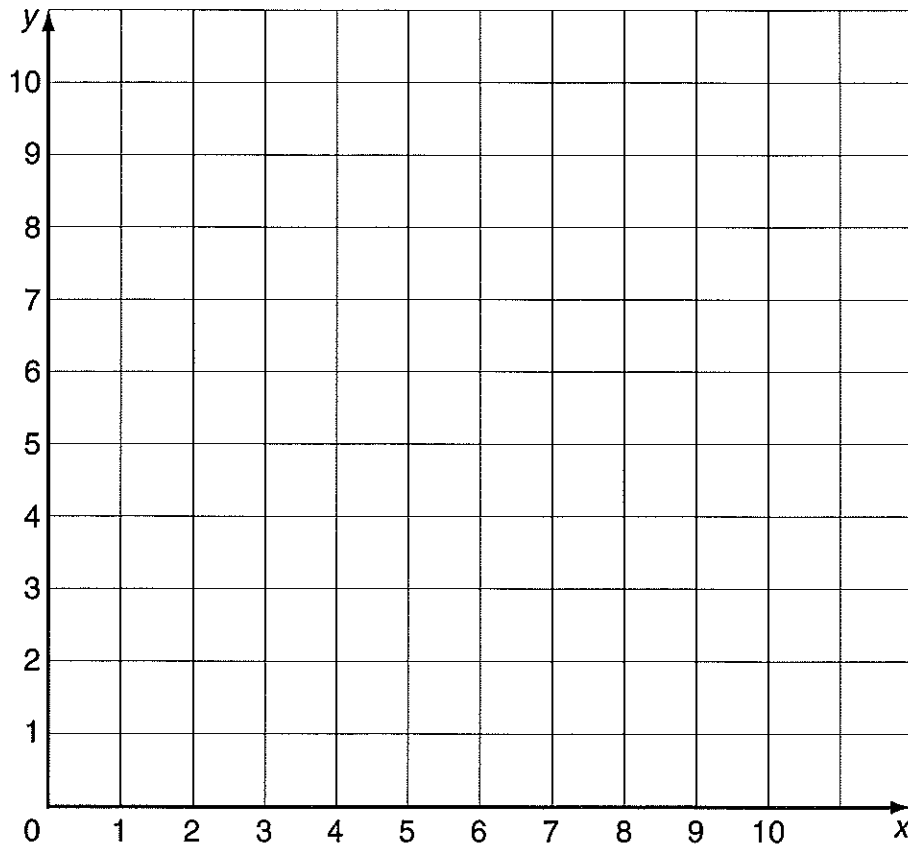

(3)

(iii) On the same grid draw and label the line $y = 2$

(1)

(iv) Four points, whose co-ordinates are both integers, lie inside the triangle formed by the three lines.

Write down the co-ordinates of each point.

Answer: (.....,), (.....,), (.....,), (.....,)

(2)

(Total marks: 100)