

SURNAME FIRST NAME

JUNIOR SCHOOL SENIOR SCHOOL

ISEB

Independent Schools
Examinations Board

COMMON ENTRANCE EXAMINATION AT 13+

MATHEMATICS

LEVEL 1: NON-CALCULATOR PAPER

Monday 26 January 2015

Please read this information before the examination starts.

- This examination is 60 minutes long.
- **All** questions should be attempted.
- A formula sheet is included to help you.
- A row of dots denotes a space for your answer.
- You must show all your working or you may receive no marks.
- Answers given as fractions should be reduced to their lowest terms.



28315237

1. (a) What is the value of the 8 in the number 2489?

Circle the answer written in words in the box below.

eight	eighty	eight hundred	eight thousand
--------------	---------------	----------------------	-----------------------

(1)

(b) Write these numbers in order of size, starting with the smallest.

907 970 790 709

Answer: (1)

(c) Write a number in each box to make the statements below correct.

(i) $34 + \square = 40$ (1)

(ii) $8 \times \square = 56$ (1)

(iii) $\square - 8 = 4$ (1)

(iv) $\square \div 8 = 4$ (1)

(d) Work out

(i) $327 \div 10$ Answer: (1)

(ii) 76×10 Answer: (1)

(iii) 1.4×100 Answer: (1)

(iv) $9382 \div 100$ Answer: (1)

2. You are told that $654 \times 325 = 212550$

Use this fact to work out

(i) 6540×325

Answer: (1)

(ii) 654×32.5

Answer: (1)

(iii) $212550 \div 325$

Answer: (1)

3. (i) Write $\frac{1}{2}$ as a decimal.

Answer: (1)

(ii) Write $\frac{3}{4}$ as a percentage.

Answer:% (1)

4. (a) Calculate $2800 - 473$

Answer: (2)

(b) Calculate 38×6

Answer: (2)

(c) (i) Calculate $602 \div 7$

Answer: (2)

(ii) Use your answer to part (c)(i) to work out the value of $602 \div 14$

Answer: (1)

5. (a) Ann has £19.25 and Beth has £9.89

How much money do Ann and Beth have in total?



Answer: £ (2)

- (b) Colin has £21.32

He buys a bag which costs £8.73

How much money does he have left?



Answer: £ (2)

- (c) A box of pens costs £3.25

How much would it cost to buy 8 of these boxes of pens?



Answer: £ (2)

- (d) 3 identical skateboards cost £142.20 altogether.

How much does 1 skateboard cost?



Answer: £ (2)

6. Dan is 9 years old and Emma is 12 years old.

(i) Write the ratio of Dan's age to Emma's age in its simplest form.

Answer::..... (2)

Dan and Emma share some money in the ratio of their ages.

(ii) If Dan has £15, how much does Emma have?



Answer: £ (2)

7. Work out the value of

(i) $4 + 8 \times 5$

Answer: (2)

(ii) $2 \times 3^2 + 7$

Answer: (2)

8. (i) What is 10% of 30 metres?

Answer: m (1)

(ii) Jessica throws a javelin 30 metres.
Her second throw is 20% longer.
How long is Jessica's second throw?



Answer: m (2)

9. (i) Write 32 as the product of its prime factors.

Answer: (2)

(ii) Write 320 as the product of its prime factors.

Answer: (1)

10. (i) Write each number in the following calculation correct to the nearest whole number:

$$\frac{2.98 \times 40.4}{1.85}$$

Answer: × (2)

.....

(ii) Use your answer to part (i) to **estimate** the value of:

$$\frac{2.98 \times 40.4}{1.85}$$

Answer: (2)

11. (i) What fraction of this shape is shaded?
Give your answer in its lowest terms.



Answer: (2)

(ii) There are 28 cherries in a bowl.
Paul takes $\frac{5}{7}$ of them.
How many cherries does Paul take?



Answer: (2)

(iii) Calculate $\frac{5}{8} + \frac{1}{8}$
Give your answer in its lowest terms.

Answer: (2)

12. (a) At 9 am, the temperature is -3°C .
By noon, the temperature has risen by 5°C .
What is the temperature at noon?



Answer: $^{\circ}\text{C}$ (1)

- (b) There are two different temperature scales: Celsius ($^{\circ}\text{C}$) and Fahrenheit ($^{\circ}\text{F}$).
Fred uses the following method to convert Celsius to Fahrenheit:

multiply by 2 then add 30



Use Fred's method to convert

- (i) 35° Celsius into Fahrenheit

Answer: $^{\circ}\text{F}$ (2)

- (ii) 70° Fahrenheit into Celsius

Answer: $^{\circ}\text{C}$ (2)

13. Given that $x = 2$ and $y = 3$ find the value of

(i) $5x + y$

Answer: (2)

(ii) xy

Answer: (1)

(iii) $y^2 - x$

Answer: (2)

(iv) $\frac{7x - 2y}{2}$

Answer: (2)

14. Calculate the size of each of the angles marked a , b , c , d and e

(i)

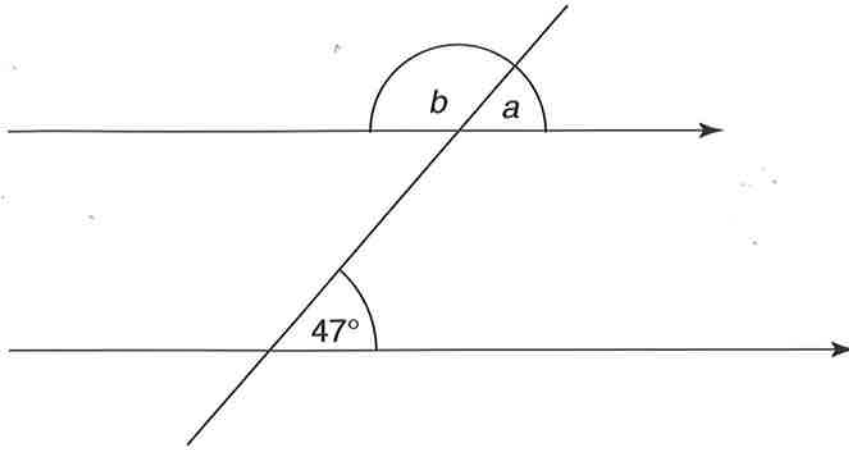

not to scale

Answer: $a = \dots\dots\dots$ (1)

$b = \dots\dots\dots$ (2)

(ii)

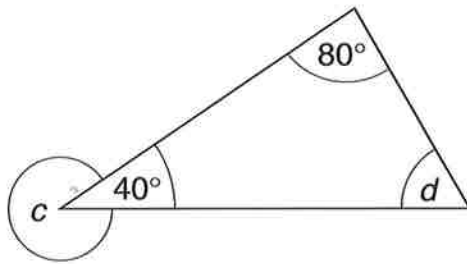

not to scale

Answer: $c = \dots\dots\dots$ (2)

$d = \dots\dots\dots$ (2)

(iii)

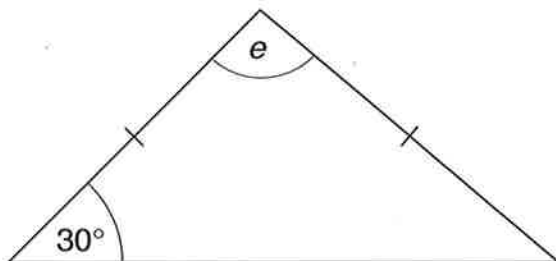

not to scale

Answer: $e = \dots\dots\dots$ (2)

15. The currency in the Czech Republic is the koruna (CZK).
The graph below can be used to convert between pounds and CZK.

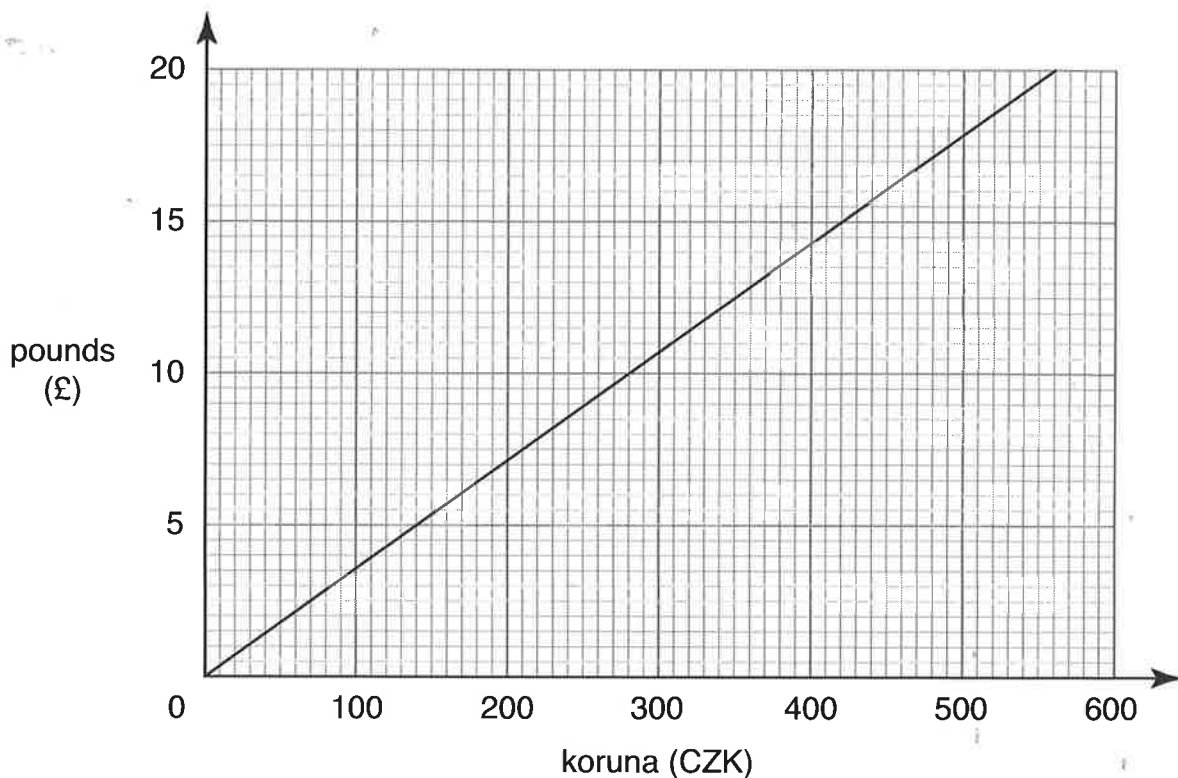

(i) Showing clearly where you take your readings on the graph, convert

(a) £10 to CZK

Answer: CZK (2)

(b) 360 CZK to pounds

Answer: £ (2)

(ii) Tomas has 36000 CZK.

Use your answer to part (i)(b) to find how much this is in pounds.

Answer: £ (1)

16. (i) Construct an equilateral triangle with sides 8 centimetres long.
(One side has been drawn for you already.)



(2)

- (ii) Draw a line of symmetry on the triangle as accurately as you can. (1)

- (iii) Measure the perpendicular height of the triangle.
Give your answer correct to the nearest millimetre.

Answer: cm (1)

- (iv) Calculate the area of the triangle.

Answer: cm² (2)

17. Look at the grid below.

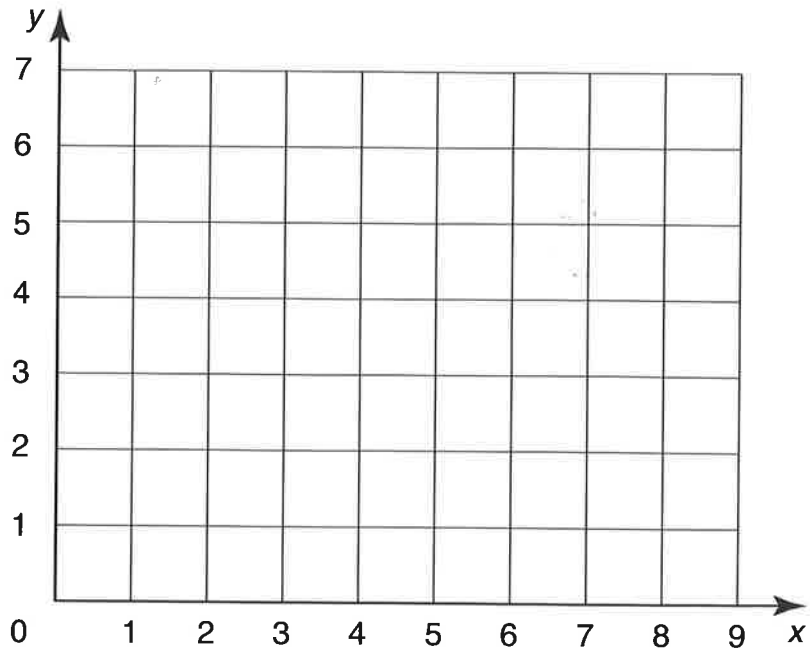

(i) On the grid, plot and label the points $A(2, 4)$, $B(5, 1)$ and $C(7, 3)$. (2)

(ii) Plot a fourth point D so that $ABCD$ is a rectangle. (1)

18. Chris writes down a number.

He multiplies it by 9 and then takes away 5

The result is 22

Find the number which Chris wrote down.

Answer: (2)

19. The patterns below are made up of grey and white squares.

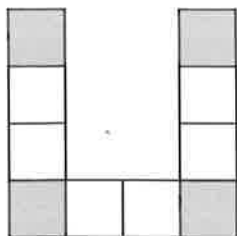

pattern 1

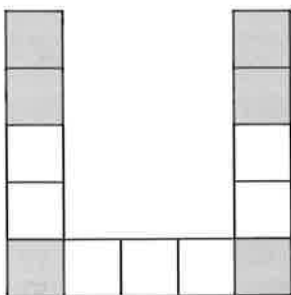

pattern 2

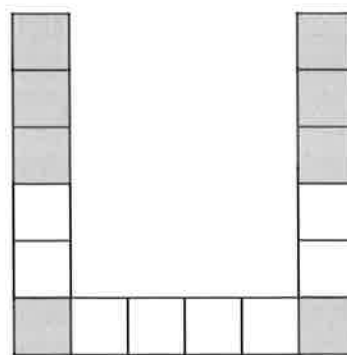

pattern 3

(i) Draw pattern 4 in the grid below.

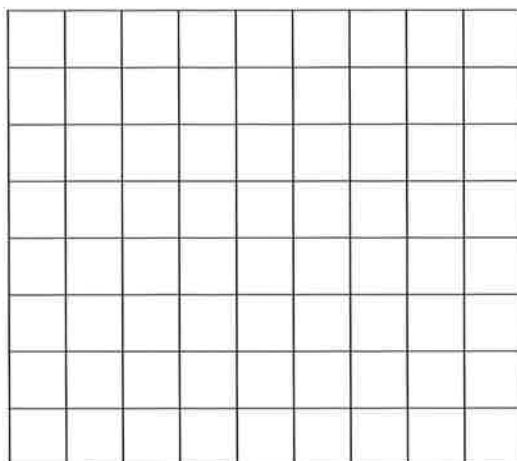

(1)

(ii) Complete the table below to show the number of grey and white squares in the patterns above.

pattern	1	2	3	4
grey squares	4	6		
white squares	6	7		

(2)

(iii) How many grey squares are there in pattern 8?

Answer: (1)

(iv) How many white squares are there in pattern 30?

Answer: (1)

TURN OVER FOR QUESTION 20

20. (a) Circle the correct answer to each part of this question.

(i) Which expression means 'start with e , halve it and then add one'?

$2e + 1$ $\frac{e+1}{2}$ $\frac{1}{2} + 1e$ $\frac{e}{2} + 1$ (1)

(ii) Which expression means 'start with w , add five and then double'?

$5w + 2$ $2w + 5$ $2(w + 5)$ $w^2 + 5$ (1)

(b) The lengths of this triangle are shown in centimetres.

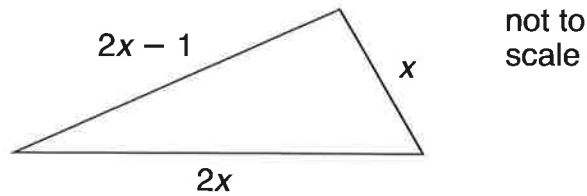

(i) Write an expression, in terms of x , for the perimeter of the triangle.

Answer: cm (1)

In fact, the perimeter is 54 cm.

(ii) Form an equation and solve it to find the value of x

Answer: $x =$ (2)

(Total marks: 100)

Formula Sheet

area

rectangle

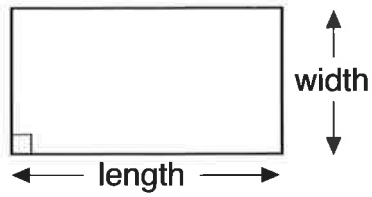

$$\text{area rectangle} = \text{length} \times \text{width}$$

triangle

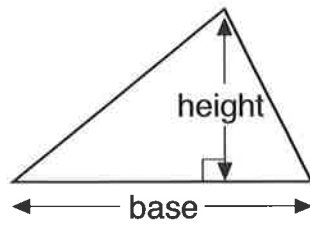

$$\text{area triangle} = \frac{1}{2} \times \text{base} \times \text{height}$$

parallelogram

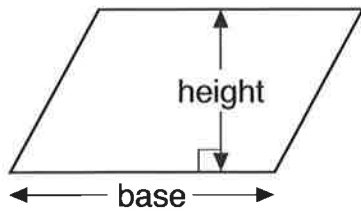

$$\text{area parallelogram} = \text{base} \times \text{height}$$

volume

cuboid

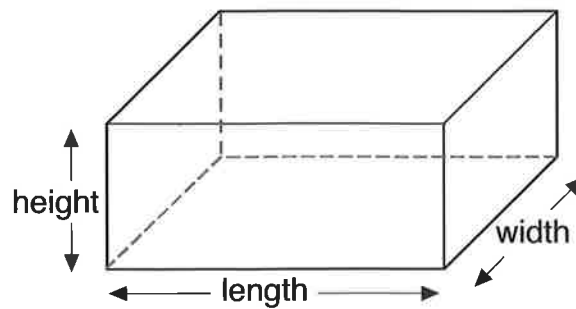

$$\text{volume cuboid} = \text{length} \times \text{width} \times \text{height}$$